



APEX DYNAMICS, INC.

**HIGH PRECISION
PLANETARY GEARBOX**

AE / AER Series



Stainless



Apex Dynamics, Inc. is the world's most productive manufacturer of servomotor drive planetary gearboxes for precision automation machinery. From our 800,000+ square foot ISO 9001:2008 manufacturing facility, based in Taichung, Taiwan, we manufacture to stock using the newest precision machine tools and quality test and inspection equipment. Complete focus on quality and precision allows us to produce our high quality gearheads at precision levels down to less than 1 arc minute (1/60 th of a degree), with consistency and high reliability.

Based on more than twenty years of accumulated manufacturing and marketing experience, plus the highest level of technical production capabilities, Apex Dynamics, Inc. designs and builds technically advanced, high speed, low backlash servo application planetary gearboxes. Our Break through patented technology (over 6 patents), provides the customer with the optimum high precision helical reducer at a reasonable price. We are continuously improving processes, finding proper and effective methods to provide customers new solutions for difficult applications, and developing new products.

The primary focus in daily operation is quality. We pride ourselves on our dedication to quality; our duty - is customer satisfaction.



APEX



AE Series

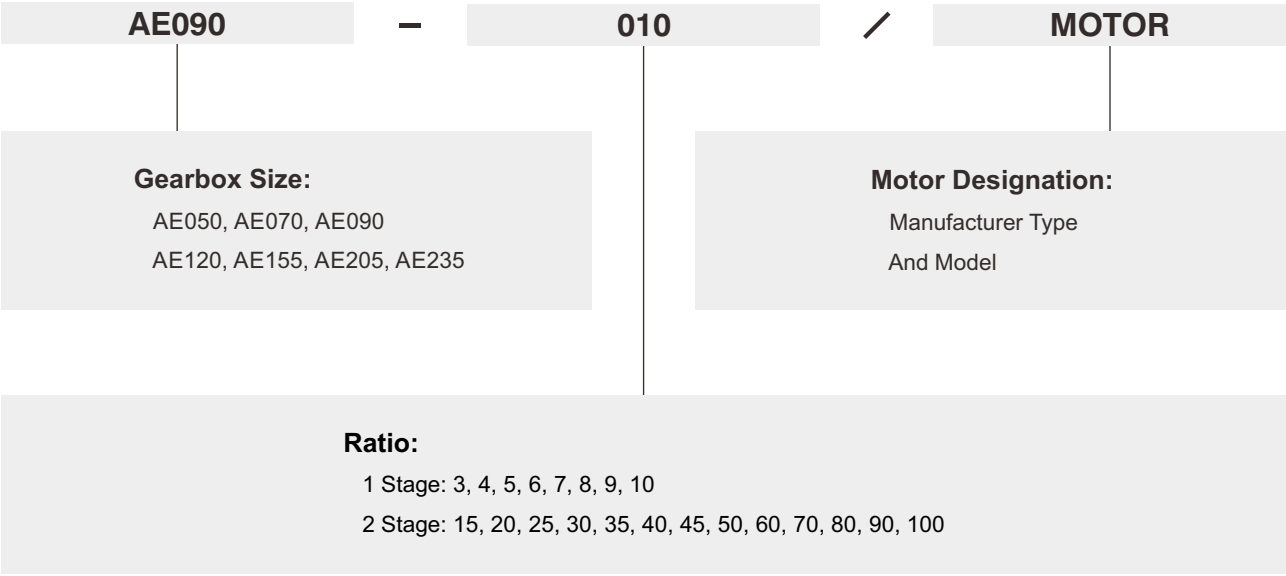

Ordering Example: AE090-010 / SIEMENS 1FT6 041-4AF71

AER Series

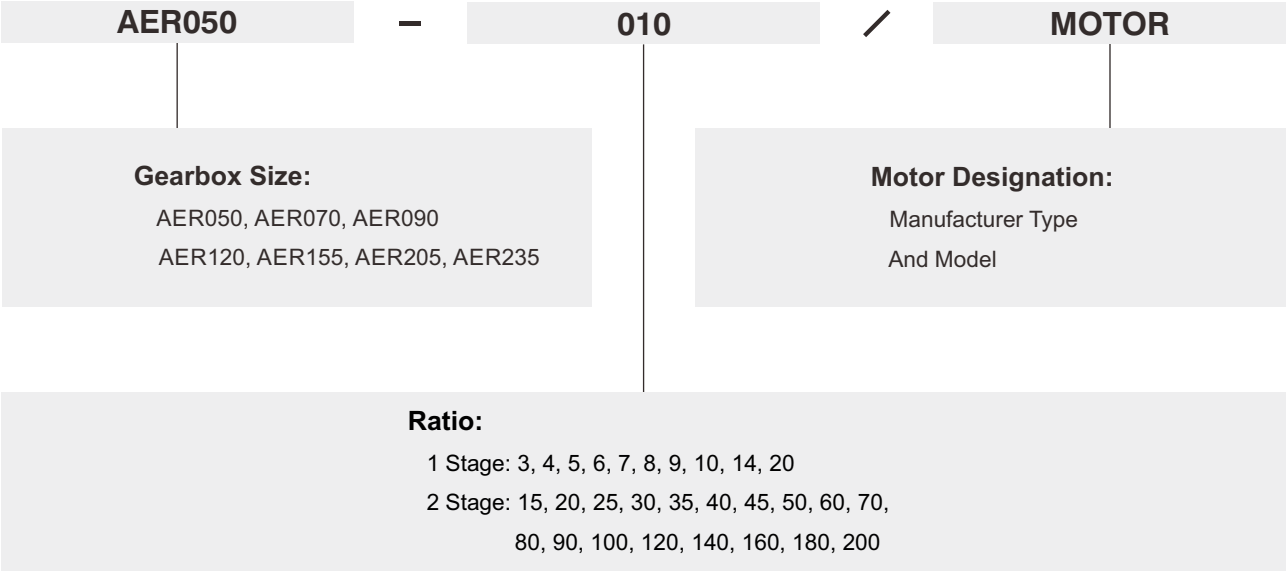

Ordering Example: AER050-010 / SIEMENS 1FT5 034-OAK71

©2017 by APEX DYNAMICS, INC.
APEX DYNAMICS, INC. reserves modification and copyrights of all technical specifications, illustrations and drawings in this catalog in allowance for continuous products development and advancement.
For the newest data and information, please visit <http://www.apexdyna.com/>

Specifications / AE Series

Gearbox Performance

Model No.	Stage	Ratio ^A	AE050	AE070	AE090	AE120	AE155	AE205	AE235	
Nominal output torque T_{2N}	1	3	20	55	130	208	342	588	1,140	
		4	19	50	140	290	542	1,050	1,700	
		5	22	60	160	330	650	1,200	2,000	
		6	20	55	150	310	600	1,100	1,900	
		7	19	50	140	300	550	1,100	1,800	
		8	17	45	120	260	500	1,000	1,600	
		9	14	40	100	230	450	900	1,500	
		10	14	40	100	230	450	900	1,500	
		2	15	20	55	130	208	342	588	1,140
			20	19	50	140	290	542	1,050	1,700
	25		22	60	160	330	650	1,200	2,000	
	30		20	55	150	310	600	1,100	1,900	
	35		19	50	140	300	550	1,100	1,800	
	40		17	45	120	260	500	1,000	1,600	
	45		14	40	100	230	450	900	1,500	
	50		22	60	160	330	650	1,200	2,000	
	60		20	55	150	310	600	1,100	1,900	
	70		19	50	140	300	550	1,100	1,800	
	80	17	45	120	260	500	1,000	1,600		
	90	14	40	100	230	450	900	1,500		
100	14	40	100	230	450	900	1,500			
Emergency Stop Torque T_{2NOT} ^B	Nm	1,2	3~100	3 times of nominal output torque						
Nominal input speed n_{1N}	rpm	1,2	3~100	5,000	5,000	4,000	4,000	3,000	3,000	2,000
Max. input speed n_{1B}	rpm	1,2	3~100	10,000	10,000	8,000	8,000	6,000	6,000	4,000
Backlash	arcmin	1	3~10	≤5	≤5	≤5	≤5	≤5	≤5	≤5
		2	15~100	≤7	≤7	≤7	≤7	≤7	≤7	≤7
Torsional rigidity	Nm/arcmin	1,2	3~100	3	7	14	25	50	145	225
Max. Radial Load F_{2B} ^C	N	1,2	3~100	702	1,377	2,985	6,100	8,460	13,050	22,000
Max. Axial Load F_{2AB} ^C	N	1,2	3~100	390	765	1,625	3,350	4,700	7,250	11,000
Max. Tilting Moment M_{2K}	Nm	1,2	3~100	20	60	170	470	840	1,500	3,100
Efficiency η	%	1	3~10	≥97%						
		2	15~100	≥94%						
Weight	kg	1	3~10	0.6	1.4	3.3	6.9	13	31	53
		2	15~100	0.9	1.6	4.7	8.7	17	35	66
Operating temp	°C	1,2	3~100	-10°C ~ 90°C						
Lubrication				Synthetic lubrication oils						
Degree of gearbox protection		1,2	3~100	IP67						
Mounting position		1,2	3~100	all directions						
Noise ^D	dB(A)	1,2	3~100	≤56	≤58	≤60	≤63	≤65	≤67	≤70

A. Ratio ($i=N_{in}/N_{out}$)

B. Max. acceleration torque $T_{2B} = 60\%$ of T_{2NOT}

C. Applied to the output shaft center at 100 rpm

D. The values are measured by gearbox with ratio 10 (1-stage) or ratio 100 (2-stage), no loading at 3,000 RPM or at the respective Nominal Input Speed by bigger model size.
By lower ratio and/or higher RPM, the values could be higher.

Max. Tilting Moment M_{2k}

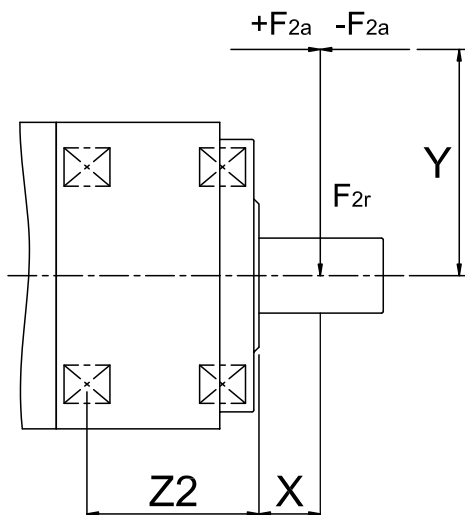

$$M_{2k} = \frac{F_{2a} * Y + F_{2r} * (X+Z2)}{1000}$$

M_{2k} : [Nm]

F_{2a}, F_{2r} : [N]

$X, Y, Z2$: [mm]

AE / AER	050	070	090	120	155	205	235
Z2 [mm]	31	42	56.5	71.5	85.5	102.5	124.5

Note : Applied to the output flange center at 100 rpm.
For more details on F_{2a} and F_{2r} please refer to page 10.

Gearbox Inertia

Model No.	Stage	Ratio ^A	AE050	AE070	AE090	AE120	AE155	AE205	AE235	
Mass moments of inertia J_1	1	3	0.03	0.16	0.61	3.25	9.21	28.98	69.61	
		4	0.03	0.14	0.48	2.74	7.54	23.67	54.37	
		5	0.03	0.13	0.47	2.71	7.42	23.29	53.27	
		6	0.03	0.13	0.45	2.65	7.25	22.75	51.72	
		7	0.03	0.13	0.45	2.62	7.14	22.48	50.97	
		8	0.03	0.13	0.44	2.58	7.07	22.59	50.84	
		9	0.03	0.13	0.44	2.57	7.04	22.53	50.63	
		10	0.03	0.13	0.44	2.57	7.03	22.51	50.56	
		2	15	0.03	0.03	0.13	0.47	2.71	7.42	23.29
			20	0.03	0.03	0.13	0.47	2.71	7.42	23.29
	25		0.03	0.03	0.13	0.47	2.71	7.42	23.29	
	30		0.03	0.03	0.13	0.47	2.71	7.42	23.29	
	35		0.03	0.03	0.13	0.47	2.71	7.42	23.29	
	40		0.03	0.03	0.13	0.47	2.71	7.42	23.29	
	45		0.03	0.03	0.13	0.47	2.71	7.42	23.29	
	50		0.03	0.03	0.13	0.44	2.57	7.03	22.51	
	60		0.03	0.03	0.13	0.44	2.57	7.03	22.51	
	70		0.03	0.03	0.13	0.44	2.57	7.03	22.51	
	80	0.03	0.03	0.13	0.44	2.57	7.03	22.51		
	90	0.03	0.03	0.13	0.44	2.57	7.03	22.51		
100	0.03	0.03	0.13	0.44	2.57	7.03	22.51			

Dimensions (1-stage, Ratio $i=3\sim 10$) / AE Series

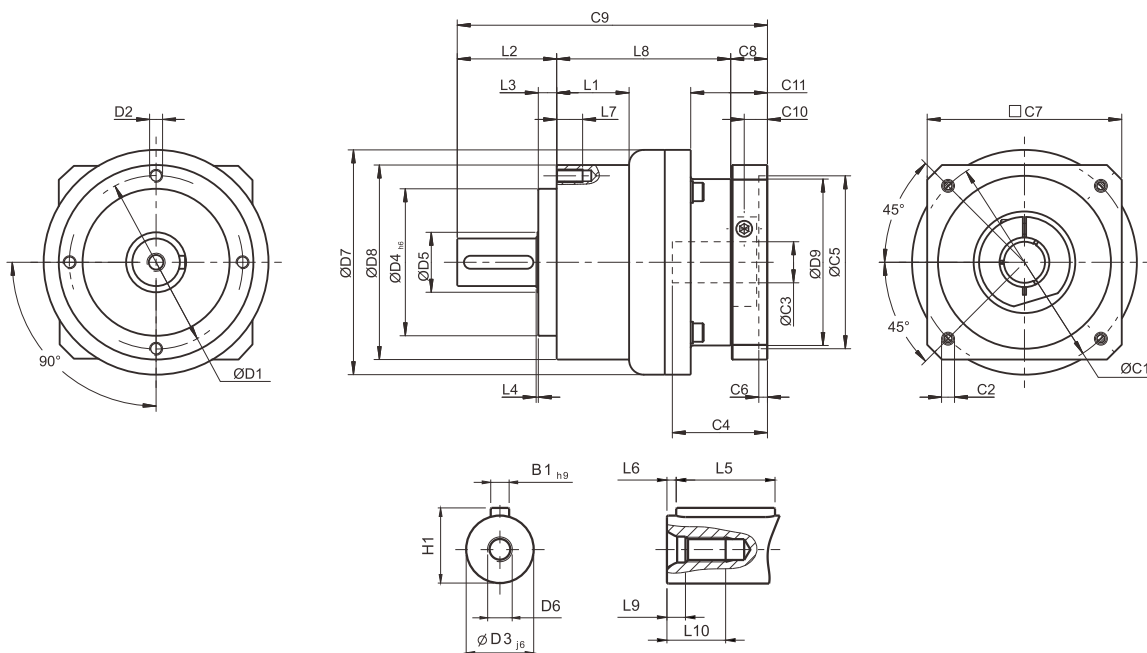

[unit: mm]

Dimension	AE050	AE070	AE090	AE120	AE155	AE205	AE235
D1	44	62	80	108	140	184	210
D2	M4 x 0.7P	M5 x 0.8P	M6 x 1P	M8 x 1.25P	M10 x 1.5P	M12 x 1.75P	M16 x 2P
D3 _{j6}	12	16	22	32	40	55	75
D4 _{h6}	35	52	68	90	120	160	180
D5	22	22	30	40	75	95	115
D6	M4 x 0.7P	M5 x 0.8P	M8 x 1.25P	M12 x 1.75P	M16 x 2P	M20 x 2.5P	M20 x 2.5P
D7	53	70	104	130	162	205	260
D8	50	70	90	120	155	205	235
D9	45.5	53.4	77	102	125	160	205
L1	--	--	33.5	38	50	--	70
L2	24.5	36	46	70	97	100	126
L3	4	6.5	8.5	17.5	15	15	18
L4	1	1	1	1.5	3	3	3
L5	14	25	32	40	63	70	90
L6	2	2	3	5	5	6	7
L7	8	10	12	16	20	22	28
L8	47	62	80.5	97	119.5	159	175.5
L9	4.5	4.8	7.2	10	12	15	15
L10	10	12.5	19	28	36	42	42
C1 ¹	46	70	100	130	165	215	235
C2 ¹	M4 x 0.7P	M5 x 0.8P	M6 x 1P	M8 x 1.25P	M10 x 1.5P	M12 x 1.75P	M12 x 1.75P
C3 ¹	≤11 / ≤12 ²	≤14 / ≤16 ²	≤19 / ≤24 ²	≤32	≤38	≤48	≤55
C4 ¹	30	34	40	50	60	85	116
C5 ¹	30	50	80	110	130	180	200
C6 ¹	3.5	8	4	5	6	6	6
C7 ¹	48	60	90	115	142	190	220
C8 ¹	19.5	19	17	19.5	22.5	29	63
C9 ¹	91	117	143.5	186.5	239	288	364.5
C10 ¹	13.25	13.5	10.75	13	15	20.75	53.5
C11 ¹	19.5	37	35.5	46	53.5	79.5	106.5
B1 _{h9}	4	5	6	10	12	16	20
H1	14	18	24.5	35	43	59	79.5

1. C1-C11 are motor specific dimensions (metric std shown). Refer to www.apexdyna.com and Design Tool to view your specific motor mounting system.
 2. AE050M1 ratio 5, 10 offers C3 ≤ 12 option; AE070M1 ratio 5, 10 offers C3 ≤ 16 option; AE090M1 offers C3 ≤ 24 option.

Dimensions (2-stage, Ratio $i=15\sim 100$) / AE Series

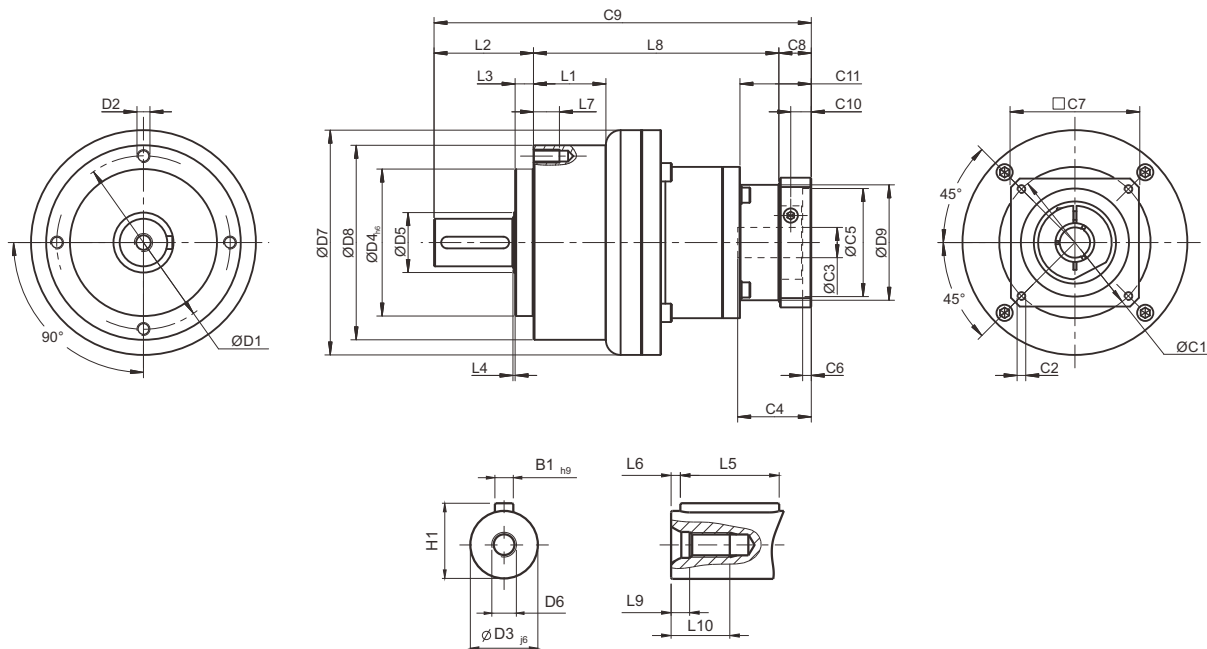

[unit: mm]

Dimension	AE050	AE070	AE090	AE120	AE155	AE205	AE235
D1	44	62	80	108	140	184	210
D2	M4 x 0.7P	M5 x 0.8P	M6 x 1P	M8 x 1.25P	M10 x 1.5P	M12 x 1.75P	M16 x 2P
D3 _{j6}	12	16	22	32	40	55	75
D4 _{h6}	35	52	68	90	120	160	180
D5	22	22	30	40	75	95	115
D6	M4 x 0.7P	M5 x 0.8P	M8 x 1.25P	M12 x 1.75P	M16 x 2P	M20 x 2.5P	M20 x 2.5P
D7	53	70	104	130	162	205	260
D8	50	70	90	120	155	205	235
D9	45.5	45.5	53.4	77	102	125	160
L1	--	--	33.5	38	50	--	70
L2	24.5	36	46	70	97	100	126
L3	4	6.5	8.5	17.5	15	15	18
L4	1	1	1	1.5	3	3	3
L5	14	25	32	40	63	70	90
L6	2	2	3	5	5	6	7
L7	8	10	12	16	20	22	28
L8	74	87.5	113.5	138.5	176	214.5	260
L9	4.5	4.8	7.2	10	12	15	15
L10	10	12.5	19	28	36	42	42
C1 ³	46	46	70	100	130	165	215
C2 ³	M4 x 0.7P	M4 x 0.7P	M5 x 0.8P	M6 x 1P	M8 x 1.25P	M10 x 1.5P	M12 x 1.75P
C3 ³	≤11 / ≤12 ⁴	≤11 / ≤12 ⁴	≤14 / ≤15.875 / ≤16 ⁴	≤19 / ≤24 ⁴	≤32	≤38	≤48
C4 ³	30	30	34	40	50	60	85
C5 ³	30	30	50	80	110	130	180
C6 ³	3.5	3.5	8	4	5	6	6
C7 ³	48	48	60	90	115	142	190
C8 ³	19.5	19.5	19	17	19.5	22.5	29
C9 ³	118	143	178.5	225.5	292.5	337	415
C10 ³	13.25	13.25	13.5	10.75	13	15	20.75
C11 ³	19.5	19.5	37	35.5	46	53.5	79.5
B1 _{h9}	4	5	6	10	12	16	20
H1	14	18	24.5	35	43	59	79.5

3. C1~C11 are motor specific dimensions (metric std shown). Refer to www.apexdyna.com and Design Tool to view your specific motor mounting system.
 4. AE050M1 C3 ≤ 12 option; AE070M1 offers C3 ≤ 12 option; AE090M1/M2 offers C3 ≤ 16/15.875 option; AE120M1 offers C3 ≤ 24.

Specifications / AER Series

Gearbox Performance

Model No.		Stage	Ratio ^A	AER050	AER070	AER090	AER120	AER155	AER205	AER235
Nominal output torque T_{2N}	Nm	1	3	9	36	90	195	342	588	1,140
			4	12	48	120	260	520	1,040	1,680
			5	15	60	150	325	650	1,200	2,000
			6	18	55	150	310	600	1,100	1,900
			7	19	50	140	300	550	1,100	1,800
			8	17	45	120	260	500	1,000	1,600
			9	14	40	100	230	450	900	1,500
			10	14	60	150	325	650	1,200	2,000
		14	-	42	140	300	550	1,100	1,800	
		20	-	40	100	230	450	900	1,500	
		15	14	-	-	-	-	-	-	-
		20	14	-	-	-	-	-	-	-
		25	15	60	150	325	650	1,200	2,000	
		30	20	55	150	310	600	1,100	1,900	
		35	19	50	140	300	550	1,100	1,800	
		40	17	45	120	260	500	1,000	1,600	
		45	14	40	100	230	450	900	1,500	
		50	14	60	150	325	650	1,200	2,000	
		60	20	55	150	310	600	1,100	1,900	
		70	19	50	140	300	550	1,100	1,800	
80	17	45	120	260	500	1,000	1,600			
90	14	40	100	230	450	900	1,500			
100	14	40	100	230	450	900	1,500			
120	-	-	150	310	600	1,100	1,900			
140	-	-	140	300	550	1,100	1,800			
160	-	-	120	260	550	1,000	1,600			
180	-	-	100	230	450	900	1,500			
200	-	-	100	230	450	900	1,500			
Emergency Stop Torque T_{2NOT} ^B	Nm	1,2	3~200	3 times of nominal output torque						
Nominal Input Speed n_{1N}	rpm	1,2	3~200	5,000	5,000	4,000	4,000	3,000	3,000	2,000
Max. Input Speed n_{1B}	rpm	1,2	3~200	10,000	10,000	8,000	8,000	6,000	6,000	4,000
Backlash	arcmin	1	3~20	≤7	≤7	≤7	≤7	≤7	≤7	≤7
		2	25~200	≤9	≤9	≤9	≤9	≤9	≤9	≤9
Torsional Rigidity	Nm/arcmin	1,2	3~200	3	7	14	25	50	145	225
Max. Radial Load F_{2RB} ^C	N	1,2	3~200	702	1,377	2,985	6,100	8,460	13,050	22,000
Max. Axial Load F_{2aB} ^C	N	1,2	3~200	390	765	1,625	3,350	4,700	7,250	11,000
Max. Tilting Moment M_{2K}	Nm	1,2	3~200	20	60	170	470	840	1,500	3,100
Efficiency η	%	1	3~20	≥95%						
		2	25~200	≥92%						
Weight	kg	1	3~20	1.0	2.1	5.8	11.2	22.4	46.8	78.0
		2	25~200	1.3	2.0	4.6	11.1	21.8	43.7	81.9
Operating temp	°C	1,2	3~200	-10°C~90°C						
Lubrication				Synthetic lubrication oils						
Degree of gearbox protection		1,2	3~200	IP67						
Mounting position		1,2	3~200	all directions						
Noise ^D	dB(A)	1,2	3~200	≤61	≤63	≤65	≤68	≤70	≤72	≤74

Gearbox Inertia

Model No.		Stage	Ratio ^A	AER050	AER070	AER090	AER120	AER155	AER205	AER235	
Mass Moments of Inertia J_i	kg · cm ²	1	3~10	0.09	0.35	2.25	6.84	23.4	68.9	135.4	
			14	-	0.31	1.87	6.25	21.8	65.6	119.8	
			20	-	0.31	1.87	6.25	21.8	65.6	119.8	
		2	15	0.09	-	-	-	-	-	-	-
			20	0.09	-	-	-	-	-	-	-
			25~100	0.09	0.09	0.35	2.25	6.84	23.4	68.9	135.4
120~200	-	-	0.31	1.87	6.25	21.8	65.6	119.8			

A. Ratio ($i=N_{in}/N_{out}$)

B. Max. acceleration torque $T_{2B} = 60\%$ of T_{2NOT}

C. Applied to the output shaft center at 100 rpm

D. The values are measured by gearbox with ratio 10 (1-stage) or ratio 100 (2-stage), no loading at 3,000 RPM or at the respective Nominal Input Speed by bigger model size.

By lower ratio and/or higher RPM, the values could be higher.

Dimensions (1-stage, Ratio $i=3\sim 20$) / AER Series

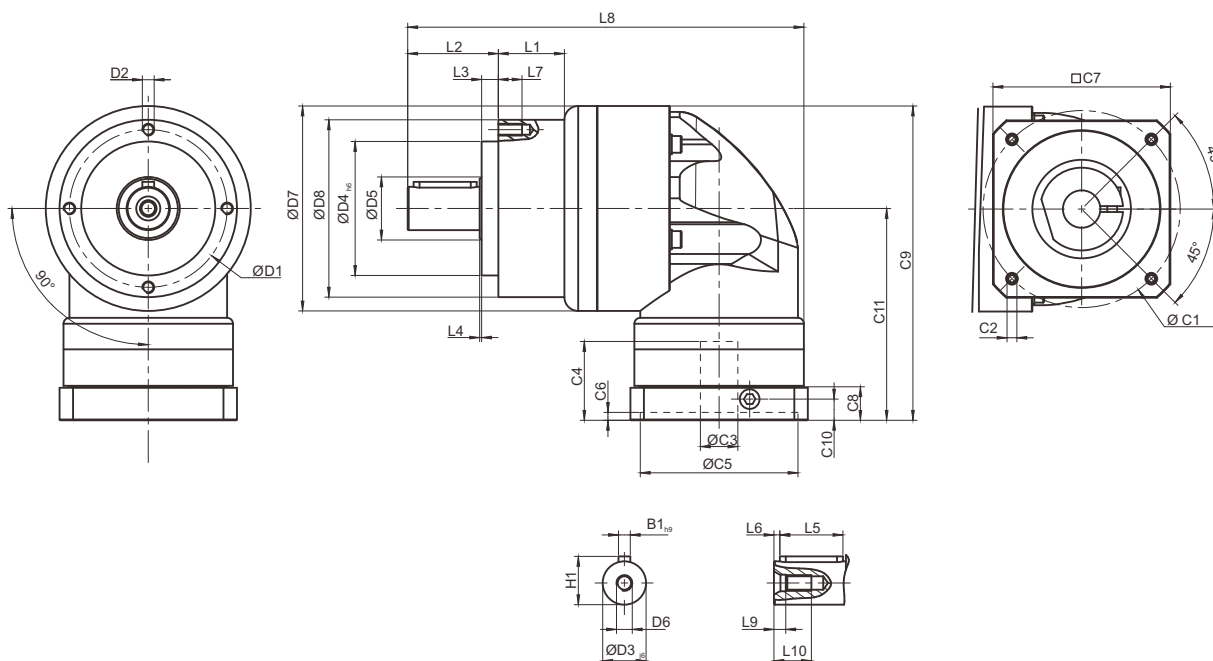

[unit: mm]

Dimension	AER050	AER070	AER090	AER120	AER155	AER205	AER235
D1	44	62	80	108	140	184	210
D2	M4 x 0.7P	M5 x 0.8P	M6 x 1P	M8 x 1.25P	M10 x 1.5P	M12 x 1.75P	M16 x 2P
D3 _{j6}	12	16	22	32	40	55	75
D4 _{h6}	35	52	68	90	120	160	180
D5	22	22	30	40	75	95	115
D6	M4 x 0.7P	M5 x 0.8P	M8 x 1.25P	M12 x 1.75P	M16 x 2P	M20 x 2.5P	M20 x 2.5P
D7	53	70	104	130	162	205	260
D8	50	70	90	120	155	205	235
L1	--	--	33.5	38	50	--	70
L2	24.5	36	46	70	97	100	126
L3	4	6.5	8.5	17.5	15	15	18
L4	1	1	1	1.5	3	3	3
L5	14	25	32	40	63	70	90
L6	2	2	3	5	5	6	7
L7	8	10	12	16	20	22	28
L8	115.5	146	201	252	324.5	379.5	461.5
L9	4.5	4.8	7.2	10	12	15	15
L10	10	12.5	19	28	36	42	42
C1 ¹	46	70	100	130	165	215	235
C2 ¹	M4 x 0.7P	M5 x 0.8P	M6 x 1P	M8 x 1.25P	M10 x 1.5P	M12 x 1.75P	M12 x 1.75P
C3 ¹	≤11 / ≤12 ²	≤14 / ≤16 ²	≤19 / ≤24 ²	≤32	≤38	≤48	≤55
C4 ¹	30	34	40	50	60	85	116
C5 ¹	30	50	80	110	130	180	200
C6 ¹	3.5	8	4	5	6	6	6
C7 ¹	48	60	90	115	142	190	220
C8 ¹	19.5	19	17	19.5	22.5	29	63
C9 ¹	100.5	116.5	159.5	199	245.5	316	398.5
C10 ¹	13.25	13.5	10.75	13	15	20.75	53.5
C11 ¹	74	81.5	107.5	134	164.5	213.5	268.5
B1 _{h9}	4	5	6	10	12	16	20
H1	14	18	24.5	35	43	59	79.5

1. C1~C11 are motor specific dimensions (metric std shown). Refer to www.apexdyna.com and Design Tool to view your specific motor mounting system.
 2. AER050M1 offers C3 ≤ 12 option; AER070M1 offers C3 ≤ 16 option; AER090M1 offers C3 ≤ 24 option.

Dimensions (2-stage, Ratio $i=15\sim 200$) / AER Series

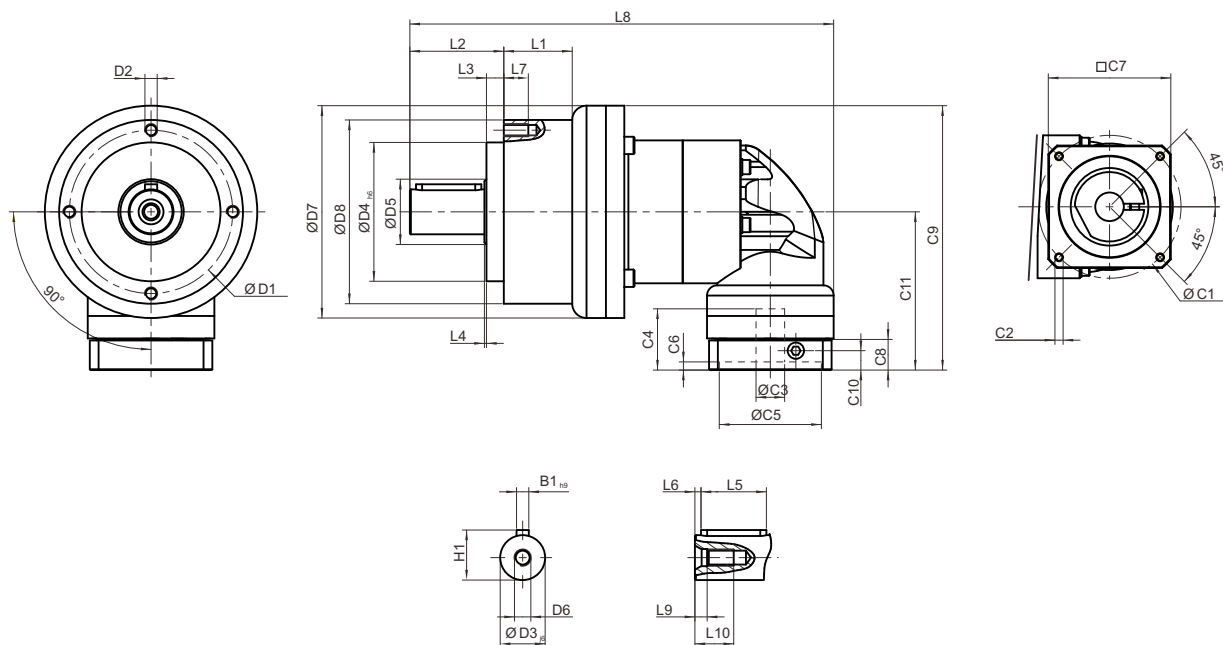

[unit: mm]

Dimension	AER050	AER070	AER090	AER120	AER155	AER205	AER235
D1	44	62	80	108	140	184	210
D2	M4 x 0.7P	M5 x 0.8P	M6 x 1P	M8 x 1.25P	M10 x 1.5P	M12 x 1.75P	M16 x 2P
D3 _{j6}	12	16	22	32	40	55	75
D4 _{h6}	35	52	68	90	120	160	180
D5	22	22	30	40	75	95	115
D6	M4 x 0.7P	M5 x 0.8P	M8 x 1.25P	M12 x 1.75P	M16 x 2P	M20 x 2.5P	M20 x 2.5P
D7	53	70	104	130	162	205	260
D8	50	70	90	120	155	205	235
L1	--	--	33.5	38	50	--	70
L2	24.5	36	46	70	97	100	126
L3	4	6.5	8.5	17.5	15	15	18
L4	1	1	1	1.5	3	3	3
L5	14	25	32	40	63	70	90
L6	2	2	3	5	5	6	7
L7	8	10	12	16	20	22	28
L8	142.5	167.5	207.5	283	358	422.5	506.5
L9	4.5	4.8	7.2	10	12	15	15
L10	10	12.5	19	28	36	42	42
C1 ²	46	46	70	100	130	165	215
C2 ²	M4 x 0.7P	M4 x 0.7P	M5 x 0.8P	M6 x 1P	M8 x 1.25P	M10 x 1.5P	M12 x 1.75P
C3 ²	≤11 / ≤12 ³	≤11 / ≤12 ³	≤14 / ≤15.875 / ≤16 ³	≤19 / ≤24 ³	≤32	≤38	≤48
C4 ²	30	30	34	40	50	60	85
C5 ²	30	30	50	80	110	130	180
C6 ²	3.5	3.5	8	4	5	6	6
C7 ²	48	48	60	90	115	142	190
C8 ²	19.5	19.5	19	17	19.5	22.5	29
C9 ²	100.5	109	133.5	172.5	215	267	343.5
C10 ²	13.25	13.25	13.5	10.75	13	15	20.75
C11 ²	74	74	81.5	107.5	134	164.5	213.5
B1 _{h9}	4	5	6	10	12	16	20
H1	14	18	24.5	35	43	59	79.5

2. C1~C11 are motor specific dimensions (metric std shown). Refer to www.apexdyna.com and Design Tool to view your specific motor mounting system.
 3. AER050M1 offers C3 ≤ 12 option; AER070M1 offers C3 ≤ 12 option; AER090M1/M2 offers C3 ≤ 16/15.875 option; AER120M1 offer C3 ≤ 24 .

Permitted Radial and Axial Loads

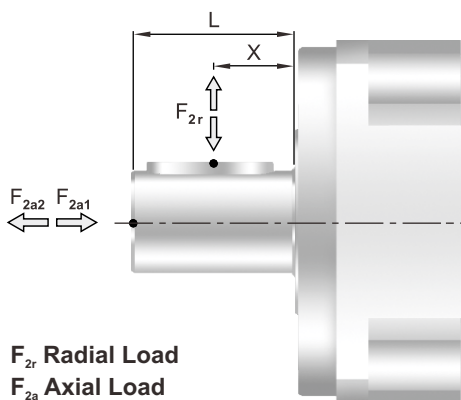

The permitted radial and axial loads on output shaft of the gearbox depend on the design of the gearbox supporting bearings. APEX use the extension straddle oversized ball bearing design. It can take heavy load from both axes.

F_{2r} Radial Load
 F_{2a} Axial Load

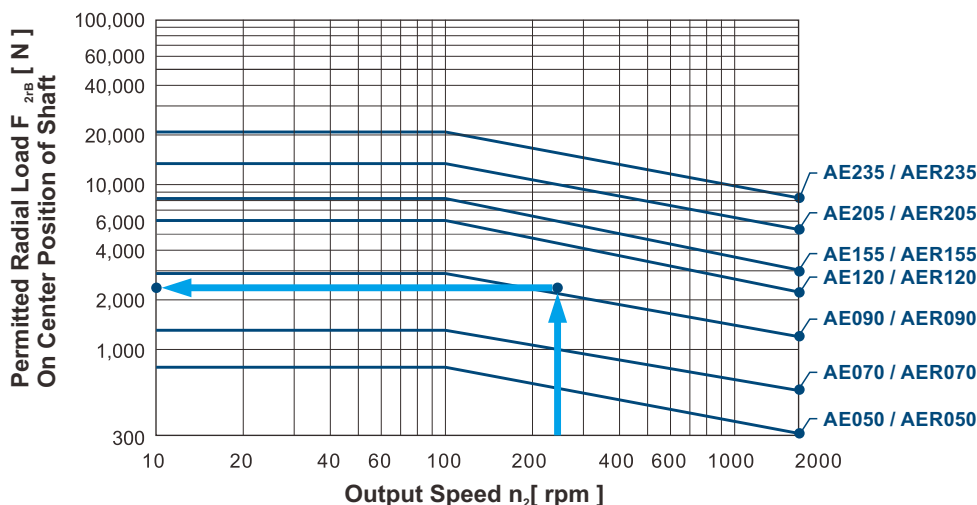

If radial force F_{2r} exert on the center of the output shaft $X=1/2 \times L$. The permitted radial load is given on left diagram.

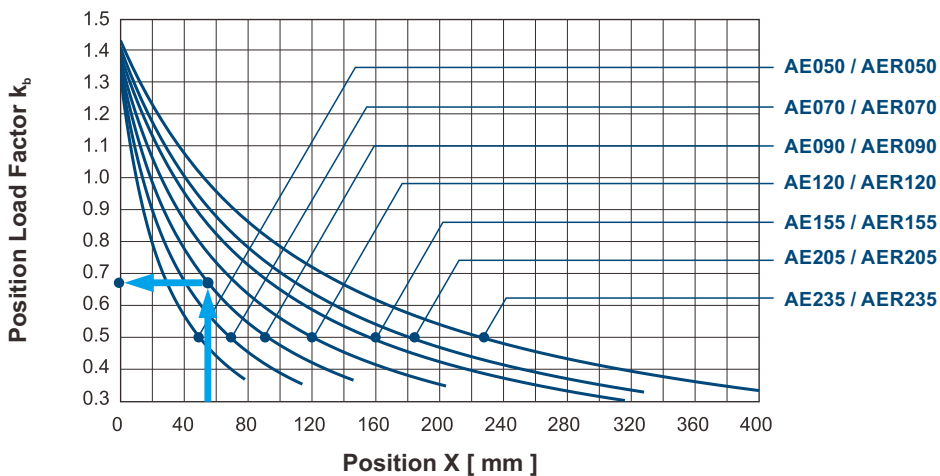

If radial force F_{2r} not exert on the center of the output shaft $X < 1/2 \times L$ or $X > 1/2 \times L$. The permitted radial and axial load can be calculated by the position load factor k_b on the left diagram.

Front Plate Option

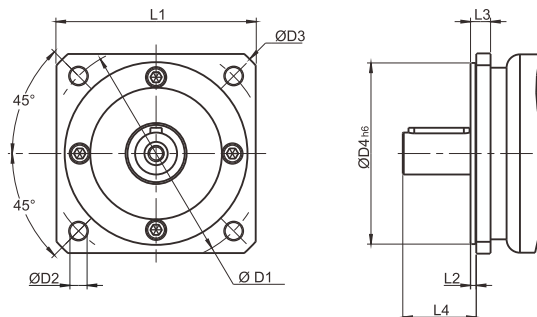

[unit: mm]

Dimension	D1	D2	D3	D4 ^{h6}	L1	L2	L3	L4
AE050(AER050)-NEMA 23	66.675	6	77	38.1	57.2	2	8	18.5
AE050(AER050)-PX60	70	5.6	80.5	50	60	2.5	8.5	18.5
AE070(AER070)-Metric	90	6.6	106	50	80	3	11	28
AE070(AER070)-NEMA 34	98.425	5.5	115	73.025	86	2.5	8	30.5
AE070(AER070)-DT90 / PX90	100	6.6	120	80	90	3	8	31
AE090(AER090)-IEC 63D5 B5	115	9	140	95	105	3	10.5	38.5
AE090(AER090)-NEMA 34	98.425	5.5	120	73.025	92	2.5	12.5	36
AE090(AER090)-DT90 / PX90	100	6.5	120	80	92	2.5	12.5	36
AE090(AER090)-NEMA 42	125.73	7	144	55.58	107	4	14.5	35.5
AE120(AER120)-NEMA 42	125.73	7.1	170	55.499	127	1.5	21.5	50
AE120(AER120)-NEMA 56	149.225	6.6	170	114.3	127	3	17.5	55.5
AE155(AER155)-B5	175	11	196	130	160	5	20	82
AE205(AER205)-B5	230	13	277	180	210	5	23	82
AE235(AER235)-B5	275	17	317	235	240	5	23	108

Selection of the optimum gearbox

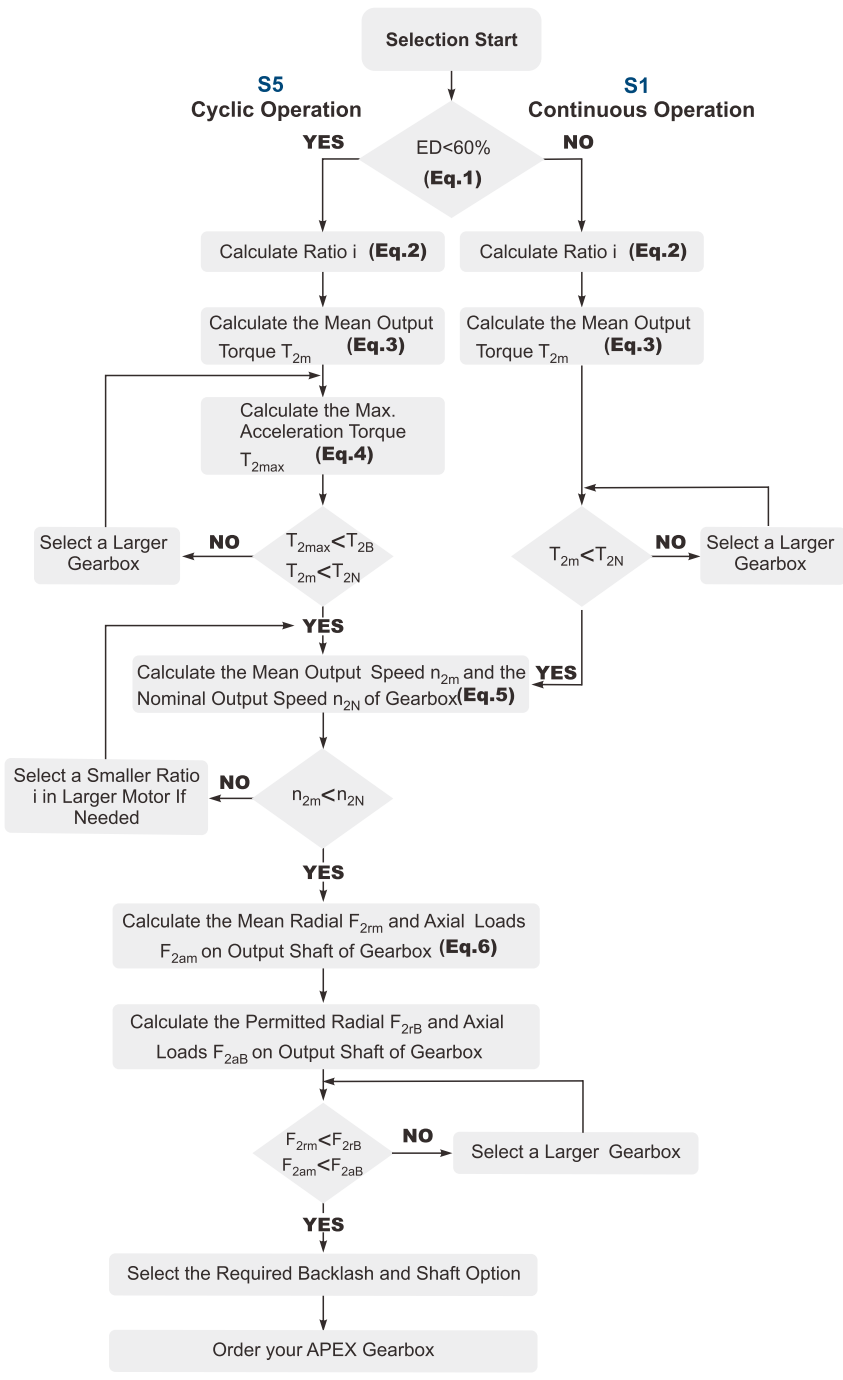

Recommended (for S5 Cycle Operation)

The general design is given for

$$\frac{J_L}{i^2} \leq 4 \times J_m$$

The optimal design is given for

$$\frac{J_L}{i^2} \cong J_m$$

J_L Load Inertia

J_m Motor Inertia

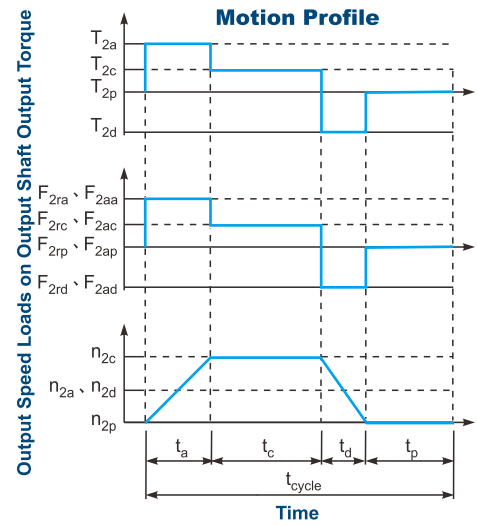

$$1. ED = \frac{t_a + t_c + t_d}{t_{cycle}} \times 100\% .$$

Index : a. Acceleration, c. Constant, d. Deceleration, p. Pause (Eq.1)

$$2. i \cong \frac{n_m}{n_{work}}$$

n_m Output Speed of the Motor
 n_{work} Working Speed (Eq.2)

$$3. T_{2m} = 3 \sqrt{\frac{n_{2a} \times t_a \times T_{2a}^3 + n_{2c} \times t_c \times T_{2c}^3 + n_{2d} \times t_d \times T_{2d}^3}{n_{2a} \times t_a + n_{2c} \times t_c + n_{2d} \times t_d}}$$

(Eq.3)

$$4. T_{2max} = T_{mB} \times i \times K_s \times \eta$$

where K_s is

K_s	No. of Cycles / hr
1.0	0 ~ 1,000
1.1	1,000 ~ 1,500
1.3	1,500 ~ 2,000
1.6	2,000 ~ 3,000
1.8	3,000 ~ 5,000

T_{mB} Max. Output Torque of the Motor

η Efficiency of the Gearbox (Eq.4)

$$5. n_{2a} = n_{2d} = \frac{1}{2} \times n_{2c}$$

$$n_{2m} = \frac{n_{2a} \times t_a + n_{2c} \times t_c + n_{2d} \times t_d}{t_a + t_c + t_d}$$

$$n_{2N} = \frac{n_{1N}}{i}$$

(Eq.5)

$$6. F_{2rm} = 3 \sqrt{\frac{n_{2a} \times t_a \times F_{2ra}^3 + n_{2c} \times t_c \times F_{2rc}^3 + n_{2d} \times t_d \times F_{2rd}^3}{n_{2a} \times t_a + n_{2c} \times t_c + n_{2d} \times t_d}}$$

$$F_{2am} = 3 \sqrt{\frac{n_{2a} \times t_a \times F_{2aa}^3 + n_{2c} \times t_c \times F_{2ac}^3 + n_{2d} \times t_d \times F_{2ad}^3}{n_{2a} \times t_a + n_{2c} \times t_c + n_{2d} \times t_d}}$$

(Eq.6)

Glossary

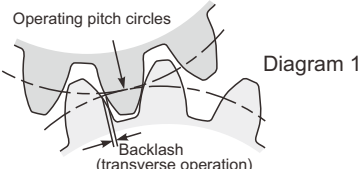
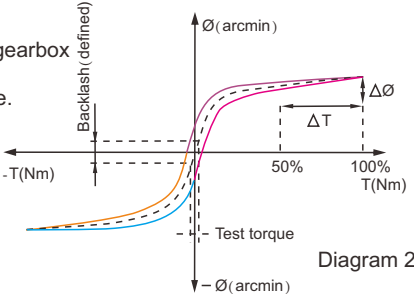
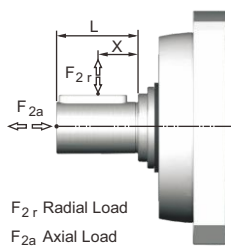
Emergency Stop Torque T_{2NOT}	Nm	The Emergency Stop Torque is the maximum permitted torque at the output of gearbox. This may happen only occasionally and may not exceed 1,000 times during the whole service life.
Max. Acceleration Torque T_{2B}	Nm	Under the Cyclic Operation (S5), the Max. Acceleration Torque is the maximum torque which can be transmitted only briefly to the output of gearbox up to 1,000 cycles/hr.
No Load Running Torque	Nm	The No Load Running Torque is the min. torque to overcome the internal friction of a gearbox without loading*.
Nominal Input Speed n_{1N}	rpm	The Nominal Input Speed is the permitted input speed of gearbox by the Continuous Operation (S1) while the housing temperature does not exceed 90°C. This value is measured at environment temperature 25°C.
Max. Input Speed n_{1B}	rpm	The Max. Input Speed is the max. permitted input speed of gearbox by the Cyclic operation (S5). This value is measured at environment temperature 25°C and serves as the absolute limit of the gearbox.
Backlash	arcmin	The Backlash is the maximum angular measurement between two teeth of gears when the transverse operation occurs (refer to Diagram 1). The arcmin is the measurement unit for the backlash. One arcmin equals 1/ 60 degree, symbolized as 1'. 
Torsional Rigidity	Nm/arcmin	Torsional Rigidity is the quotient ($\Delta T / \Delta \theta$) between the applied torque and resulting torsion angle. This value indicates how much torque is needed on the gearbox to rotate the output shaft for 1 arcmin. The Torsional Rigidity can be determined by Hysteresis Curve. Hysteresis Curve When the input shaft is locked, increase torque at the output slowly up to T_{2B} in both directions and then release the torque gradually. According to the measured torque and torsion angle, a closed curve will be acquired as in the Diagram 2. 
Radial Load And Axial Load	N	The permitted radial and axial loads on output shaft of the gearbox depend on the design of the gearbox supporting bearings. For more information, please refer to APEX website. 
Efficiency η	%	The transmission efficiency of the gears inside a gearbox (without friction).
Operating Temperature	°C	The Operating Temperature indicates the temperature of gearbox housing.
Degree of Protection		IP code stands for International Protection standard. The IP65 as example: the first IP number stands for protection degree against dust; the second IP number stands for protection against liquid.
Lubrication		APEX uses synthetic lubrication grease. Alternate greases are available, please contact APEX.
Running Noise	dB(A)	The Running Noise is measured depends on gearbox size, the ratio and the speed*. Higher speed usually induces higher noise level, while higher ratio induces lower noise level.
Moment of Inertia J_1	kg.cm ²	The Moment of Inertia J_1 is a measurement of the effort applied to an object to maintain its momentary condition at rest or rotating.
Breakaway Torque	Nm	The Breakaway Torque is the minimum torque to start the rotation from the input side of gearbox. A smaller size or a higher ratio gearbox requests less Breakaway Torque.
Back Driving Torque	Nm	The Back Driving Torque is the minimum torque to start the rotation from the output side of gearbox. A larger size or a higher ratio gearbox requires greater Back Driving Torque.

* This value is measured at environment temperature 25°C and the input speed 3,000 rpm. If the Nominal Input Speed n_{1N} of gearbox is lower than 3,000 rpm, this value is measured by that specific Nominal Input Speed.

Liability Disclaimer:

APEX DYNAMICS, INC. endeavors to ensure the accuracy and reliability of the data in catalog.

APEX accepts no liability, whether in any form, for any loss or damage arising from any inaccuracy or omissions of this catalog.



**APEX TAIWAN NORTH
ANDTEK AUTOMATION CO.,LTD**
TEL +886-02-82262655
13F-5, NO.2, Jian 8th Rd., Jhonghe Dist., New
Taipei City 235, TAIWAN
sales@andtek.com.tw
www.apexdyan.com



**APEX TAIWAN CENTRAL
ANDTEK AUTOMATION CO.,LTD**
TEL +886-04-23594286
9F-6, NO.925, Sec.4, Taiwan Blvd., Xitun Dist.
Taichung City 407, TAIWAN
sales@andtek.com.tw
www.apexdyan.com



**APEX TAIWAN SOUTH
MEN JENN ELECTRIC CO., LTD.**
TEL +886-06-2337332*6
NO.774, Zhonghua Rd., Yongkang Dist., Tainan
City 710, TAIWAN
menjenn@ms24.hinet.net
www.apexdyan.com



APEX TAIWAN INC. SHANGHAI
TEL +86-21-69220577
NO.128 ZHUHUYING Road QINGPU Industry Area,
Shanghai, CHINA
sales@apexdyan.com
www.apexdyan.cn



APEX DYNAMICS SHENZHEN, LTD.
TEL +86-755-84516325
NO. 1102A of D area, CFG mansion, Bao Yuan
Road, Bao' an District, Shenzhen, CHINA.
sales@szapexdyan.com
www.szapexdyan.com



APEX DYNAMICS BEIJING, LTD.
TEL +86-10-69570691
NO. 1, Yao Ping Road, Song Zhuang Town, Tongzhou
District, Beijing, CHINA.
bjapexdyan@163.com
www.bjapex.cn



CHONGQING APEX DYNAMICS CO., LTD.
TEL +86-23-67686860
406, Building 5, NO. 68, Jinyu Avenue, Beibu New
Area, Chongqing, CHINA
sales@cqapexdyan.com
www.apexdyan.com



APEX (XIAMEN) DYNAMICS TECHNOLOGY CO., LTD.
TEL +86-0592-720-5279
Unit B-3, 1F., NO. 129, Jingquan Road, Jimei District,
Xiamen, Fujian, CHINA
sales@xmmapexdyan.com
www.xmapexdyan.com



APEX DYNAMICS USA, INC.
TEL +1-631-2449040
885 Marconi Avenue Ronkonkoma, NY 11779
U.S.A.
sales@apexdynamicsusa.com
www.apexdynamicsusa.com



APEX DYNAMICS KOREA INC
TEL +82-31-8179992
7-5, Aenigol-gil, Ilsandong-gu, Goyang-si, Gyeonggi-do,
Republic of Korea 10301
sales@apexdynakorea.co.kr
www.apexdynakorea.co.kr



APEX DYNAMICS JAPAN
TEL +88-092-4511202
1-3-46, Hamnichibasi, Hakata-ku, Fukuoka,
812-0897, JAPAN
sales@apexdyan.jp
www.apexdyan.jp



APEX DYNAMICS SINGAPORE PTE LTD
TEL +65-62-662228
3 South Buona Vista Road, #05-15 & #06-15.
SINGAPORE 118136
sales@apexdyan.com.sg
www.apexdyan.com.sg



APEX DYNAMICS (THAILAND) CO., LTD.
TEL +66-2-326623
87 Soi Ladkrabang 30, Ladkrabang, Ladkrabang,
Bangkok 10520, Thailand
Apexthal2010@gmail.com
www.apexdyan.co.th



APEX DYNAMICS BV
TEL +31-492-509995
Churchillaan 101 5705 BK Helmond, NETHERLANDS
sales@apexdyan.nl
www.apexdyan.be



**APEX DYNAMICS
POLSKA SP. Z O.O.**
TEL +48-12-6304728
Ul. Krakowska 50, 32-083 Balice, Poland
sales@apexdyan.pl
www.apexdyan.pl



APEX DYNAMICS SPAIN, S.L.
TEL +34-93-6562990
Carretera Laureà Miró, 407
08980 - Sant Feliu de Llobregat, Barcelona, SPAIN
apexdyan@apexdyan.es
www.apexdyan.es



Big Diamond Trading Company LLC
TEL +968-94268885
2nd floor, Regus, Tamimah building, Al
Wattayah, Muscat, Oman
ar.gorji@diamondtradings.com



APEKS DINAMIK REDUKTOR DISLI SAN TIC AS
TEL +90-232-4589960
10053 SOKAK NO: 9 A.O.S.B. CIGLI- IZMIR - TURKEY
sales@apexdyan.com.tr
www.apexdyan.com.tr



APEX DYNAMICS AUSTRALIA PTY LTD.
TEL +613-95-852739
36 Taunton Drive,Cheltenham, Victoria 3192
AUSTRALIA.
sales@apexdyan.com.au
www.apexdyan.com.au



APEX DYNAMICS (I) JIV
TEL +91-9607927142
Shop No. 02, S. No. 100/5, Pune-Satara Highway,
Ambegaon Khurd, Pune-411046 Maharashtra, India
sales@apexdyan.co.in
www.apexdyan.co.in



APEX DYNAMICS FRANCE SAS
TEL +33-160-135097
11 - Burospace - 91570 - Bièvres, France
info@apexdyan.fr
www.apexdyan.fr



APEX DYNAMICS SWEDEN AB
TEL +46-75-2424444
Fredrikbergsgatan 2 SE-573 92 Tranås, SWEDEN
sales@apexdyan.se
www.apexdyan.se



PT.APEX DYNAMICS INDONESIA
TEL +62 21 2928 3681
Rukan Aralia Blok HY43 no.11, Harapan Indah II,
Bekasi - Jawa Barat, INDONESIA 17214
sales@apexdyan.co.id
www.apexdyan.co.id



APEX DYNAMICS GERMANY GMBH
TEL +49-7171 798069-0
Marie-Curie-Straße 25 D-73529 Schwäbisch Gmünd
wernerlangner@apexdynamics.de
www.apexdynamics.de



APEX DYNAMICS CZECH S.R.O.
TEL +420-577-663877
tř. Tomáše Bati 1851 765 02 Otrokovice Česká
REPUBLIKA
info@apexdynaczech.cz
www.apexdynaczech.cz



APEX DYNAMICS РОССИЯ
TEL +7-495-2255452
TEL +7-495-6462422
г.Москва,ул. Южнопортовая, дом 7, строение
"С", 3-й этаж
info@apexdynarussia.ru
www.apexdynarussia.ru



APEX DYNAMICS MIDLANDS LTD
TEL +44-0121-737-1170
Heath House, Cheadle Rd, Uttoxeter,
ST14 7BY, U K
mikeg@apexdynauk.com
www.apexdynauk.com



APEX DYNAMICS SWITZERLAND AG
TEL +41-55-4517020
Obergasse 40, CH-8854 Galgenen, Switzerland
info@apexdyan.ch
www.apexdyan.ch



APEX DYNAMICS MOTION (M) SDN BHD
TEL +60 7267 4228
Block A1-2, #35-03, Mercu 1 Jalan Tanjung Puteri 1,
R & F Tanjung Puteri, Johor Bahru 80300, Johor.
sales@apexdyan.com.sg
www.apexdyan.com.sg



APEX DYNAMICS BRAZIL
TEL +55-47-30298700
Rua Senador Petrônio Portela, 47-Bloco 5, Zona
Industrial Norte-CEP 89218-575-Joinville (SC)
lucan@neoyama.com.br
adriano.tuarte@neoyama.com.br
www.neoyama.com.br



APEX DYNAMICS ITALY SRL
TEL +39 02 36634521
VIA E. DE AMICIS, 2-20091 BRESSO (MI)
info@apexdynamics.it
www.apexdynamics.it



APEX DYNAMICS AUSTRIA GmbH
TEL +43 720788416
Dr. Hans-Lechner-Strasse 6,
5071 Wals-Siezenheim
info@apexdynamics.at
www.apexdynamics.at



UAB "APEKSO DINAMIKA"
TEL +370 52078165
Medaus g. 28A,
Medininku k., Vilniaus r. Sav.
LT-13192
info@apexdyan.lt
www.apexdyan.lt



APEX DYNAMICS DENMARK
TEL +45 73121260
Grundtvigs Allé 165, 6400
Sønderborg, Denmark
sales@apexdyan.dk
www.apexdyan.dk



APEX DYNAMICS ISRAEL
TEL +972-3-6470471
17 Hamefalsim St., Kiryat Arye,
Petach-Tikva 4951447
Sales@apexdynamics.co.il
www.apexdynamics.co.il



APEX DYNAMICS SLOVAKIA S.R.O.
TEL +421919400476
Trenčianska cesta 887/52, 957 01
Bánovce nad Bebravou, Slovak republic
office@apexdyan.sk
www.apexdyan.sk



APEX DYNAMICS, INC.

No10. Keyuan 3rd RD.Situn District, Taichung City 40763, Taiwan (R.O.C)

Tel:886-4-24650219 | Fax:886-4-24650118

sales@apexdyan.com | <http://www.apexdyan.com>

APEX-2024-07-AE/AER SERIES-1.0-TWN

Printed in Taiwan



APEX DYNAMICS VIETNAM TRADING SERVICES CO., LTD
TEL +84-028-35350628
267 Duong so 7, P. Binh Tri Dong B, Q, Binh Tan,
Thanh pho Ho Chi Minh,Vietnam
Sales@apexdyan.vn
www.apexdyan.vn

